

DOOR WIDTH	CLOSER SIZE	CLOSING FORCE in Nm (kpm)	NO HOLD	HOLD OPEN 90 °	HOLD OPEN 105 °
			PRODUCT CODE		
Up to 750mm	1	20 (2.0)	8801-00*	8801-90*	8802-105
751 to 950mm	2	27 (2.7)	8802-00*	8802-90*	
951 to 1150mm	3	33 (3.3)	8803-00*	8803-90*	
SHIPPING WEIGHT 4:46KG					

SELECT SIZE SMALLER FOR INTERNAL DOORS.
 SELECT SIZE LARGER FOR DOORS IN SEVERE CONDITIONS.
 *5mm, 10mm and 15mm SPINDLE EXTENSION
 OPTIONS AVAILABLE.
 ** STANDARD SPINDLE SIZE

BODY UNIT AND FIXINGS	PRODUCT CODE
DUMMY BODY UNIT	TC-8800

APPLICATIONS
 Double or single action.
 Centre hung offset pivot with special arm.
 Side load and end fittings.
 65mm pivot point & 70mm pivot point.

CLOSING ADJUSTMENT

MAXIMUM DOOR LEAF 100Kgs

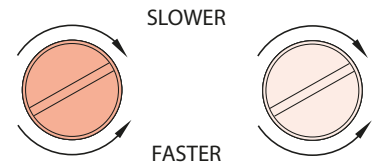
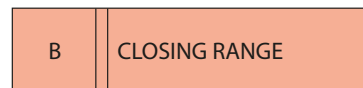
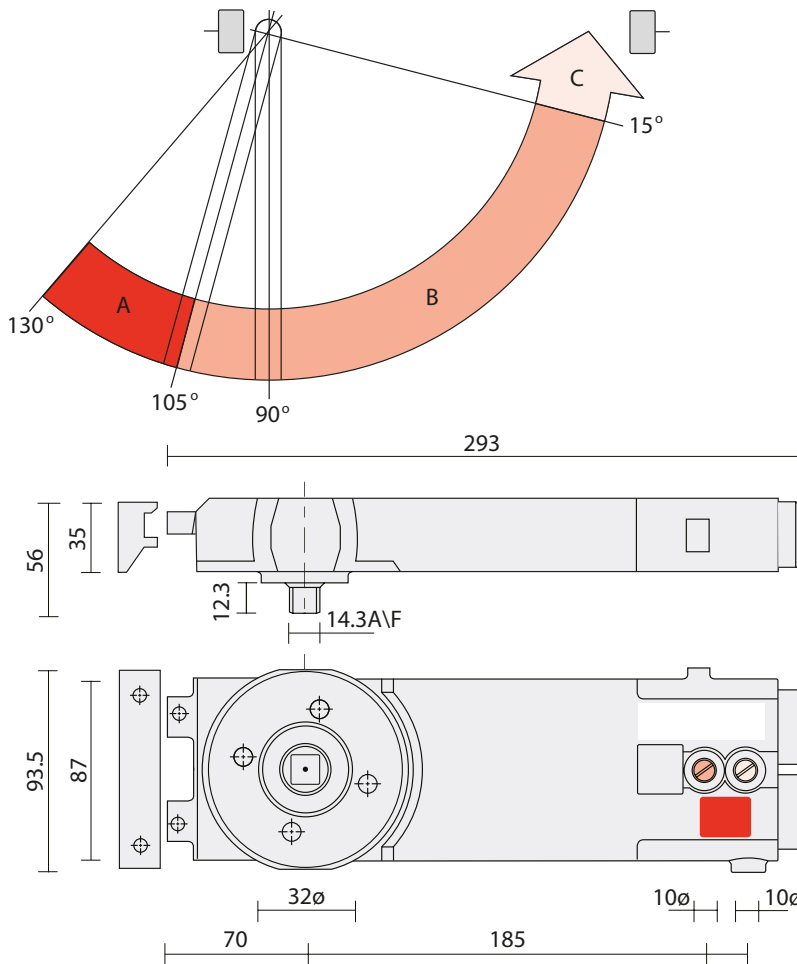

MAXIMUM TWO TURNS
 IN EITHER DIRECTION

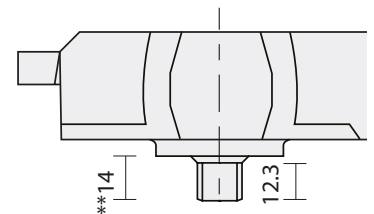

GUARANTEE

AXIM TRANSOM CLOSERS AND ACCESSORIES ARE GUARANTEED FOR 30 MONTHS FROM THE DATE OF MANUFACTURE AGAINST DEFECT IN MATERIAL AND WORKMANSHIP. THIS GUARANTEE IS VOID IF THE PRODUCT HAS BEEN INCORRECTLY INSTALLED OR DAMAGED IN USE. CLAIMS FOR DAMAGE INCURRED OR WORK DONE THEREON WILL NOT BE ACCEPTED.

AXIM RESERVE THE RIGHT TO UPDATE ITS PRODUCT INFORMATION WITHOUT PRIOR NOTICE

SCALE	NTS @A4
DATE	NOVEMBER 2019
For scaled technical or CAD drawings, please contact AXIM.	