



TITLE	UNIVERSAL CONCEALED OVERHEAD TC-9900 SERIES TRANSOM CLOSER	SHEET No. <b>1:11</b>
SUB TITLE	TECHNICAL INFORMATION	

The Axim 9900 series door closer has been developed to provide the market with a truly universal door closer. This closer will offer the answer for new installations and for door maintenance where other leading transom closers have failed and a replacement closer is necessary.

**MODEL SELECTION TABLE**

DOOR WIDTH	CLOSER SIZE	CLOSING FORCE in Nm	NO HOLD	HOLD OPEN 90°
			PRODUCT CODE	
Up to 750mm	1	20	9901-00	9901-90
751 to 950mm	2	27	9902-00	9902-90
951 to 1150mm	3	33	9903-00	9903-90
SHIPPING WEIGHT 4.5 kgs				

SELECT A SIZE SMALLER FOR INTERNAL DOORS  
SELECT SIZE LARGER FOR DOORS IN SEVERE CONDITIONS

BODY UNIT AND FIXINGS	PRODUCT CODE
DUMMY BODY UNIT	TC-9900

**APPLICATIONS**

Double or single action.  
Centre hung or offset pivot with special arm.  
Side load and end load fittings.  
70mm pivot point

**REPLACEMENTS**

Will replace Axim 8800 series, Dorma, Peters Jackson, Newman, Tonks, Ryobi and other leading transom closers without costly modifications to door or frame.  
Universal fittings included.

**TECHNICAL INFORMATION**

Independent, fully adjustable closing and latching speed controls with captivated screws preventing accidental removal.

3 power sizes, suitable for doors up to 1150mm wide and 100 Kgs. in weight.

Mechanical backcheck protects doors and closer when opening past 105°.

Fitting instructions are supplied with each body unit with a separate sheet covering replacement procedures.

**GUARANTEE**

AXIM TRANSOM CLOSERS ARE GUARANTEED FOR 30 MONTHS FROM THE DATE OF MANUFACTURE AGAINST DEFECT IN MATERIAL AND WORKMANSHIP. THIS GUARANTEE IS VOID IF THE PRODUCT HAS BEEN INCORRECTLY INSTALLED OR DAMAGED IN USE. CLAIMS FOR DAMAGE INCURRED OR WORK DONE THEREON WILL NOT BE ACCEPTED.

AXIM RESERVE THE RIGHT TO UPDATE THIS PRODUCT INFORMATION WITHOUT PRIOR NOTICE

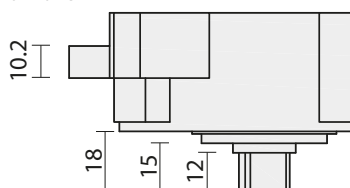

**CLOSING ADJUSTMENT**

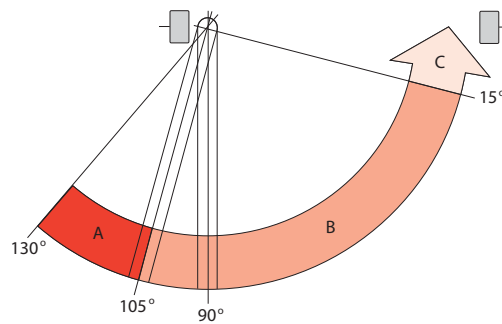

Independent valve screws permit closing speed adjustment from fully open to 15° and 15° to closed.

A	BACKCHECK
B	CLOSING RANGE
C	LATCHING RANGE

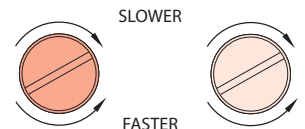

MAXIMUM TWO TURNS

IN EITHER DIRECTION

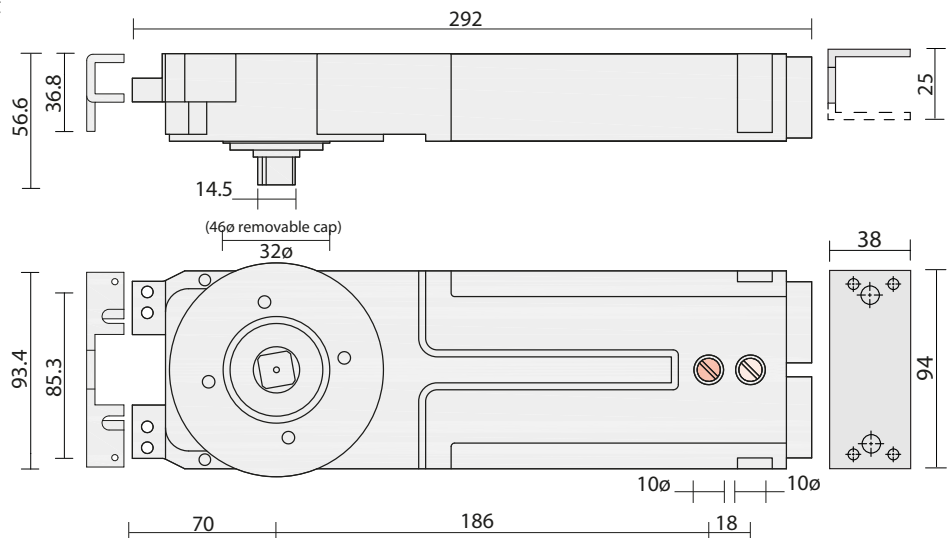

SCALE	NTS @A4
DATE	AUGUST 2017
For scaled technical or CAD drawings, please contact AXIM.	